

## Sealed Choke Coil SDET25201T type

### ■ Features

Low profile : 2.5mm x 2.0mm x 1.0mm

Low coil resistance with large currents.

High magnetic shield construction should actualize high resolution for EMC protection.

100% lead (Pb) free meet RoHS standard

### ■ Application

Cellular phones, LCD displays, HDDs, DVCs, DSCs, PDAs etc..

### ■ Outline Dimensions

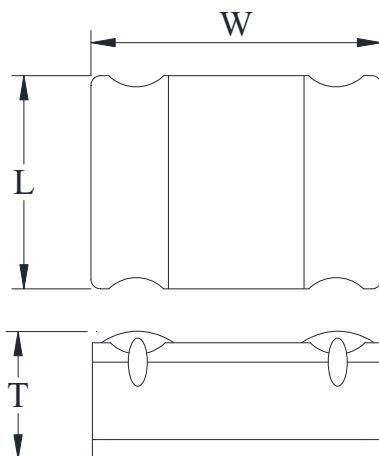

Code	Dimensions (mm)
L	2.0 ± 0.2
W	2.5 ± 0.2
T	1.0 Max.

Note : This graph is in regard to outline dimensions spec. For outer appearance, please refer to actual product.

### ■ Recommend Land Pattern Dimensions

The customer shall determine the land dimensions shown below after confirming and safety.

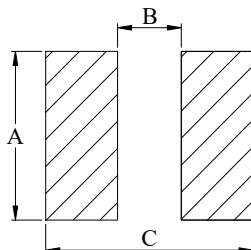

A	2.1
B	0.8
C	2.6

Unit : mm

■ Specifications

Part Number	L0 Inductance ( $\mu$ H ) @ (0A)	R <sub>dc</sub> ( m $\Omega$ )		Heat Rating Current DC Amps. I <sub>dc</sub> ( A )		Saturation Current DC Amps. I <sub>sat</sub> ( A )	
		Typical	Maximum	Typical	Maximum	Typical	Maximum
SDET25201T-R24MS	0.24	29	35	3.60	3.24	4.60	4.14
SDET25201T-R47MS	0.47	35	43	2.70	2.43	2.90	2.61
SDET25201T-R68MS	0.68	48	58	2.50	2.25	2.70	2.43
SDET25201T-1R0MS	1.0	67	81	1.98	1.78	2.10	1.89
SDET25201T-1R5MS	1.5	95	114	1.70	1.53	1.80	1.62
SDET25201T-2R2MS	2.2	135	162	1.50	1.35	1.55	1.39
SDET25201T-3R3MS	3.3	207	249	1.2	1.04	1.3	1.17
SDET25201T-4R7MS	4.7	269	323	1.08	0.97	1.20	1.08
SDET25201T-6R8MS	6.8	404	485	0.81	0.73	0.85	0.77
SDET25201T-100MS	10.0	507	609	0.80	0.72	0.73	0.65
SDET25201T-150MS	15.0	928	1114	0.45	0.40	0.55	0.49
SDET25201T-220MS	22.0	1312	1574	0.35	0.31	0.45	0.40

\* : If you require another part number please contact with us.

\*\* : Inductance Tolerance  $\pm$  20%

Note 1. : All test data is referenced to 25 $^{\circ}$ C ambient.

Note 2. : Test Condition:1MHz, 1.0Vrms

Note 3. : I<sub>dc</sub> : DC current (A) that will cause an approximate  $\Delta$ T of 40 $^{\circ}$ C

Note 4. : I<sub>sat</sub> : DC current (A) that will cause L0 to drop approximately 30%

Note 5. : Operating Temperature Range -55 $^{\circ}$ C to +125 $^{\circ}$ C

Note 6. : The part temperature (ambient + temp rise) should not exceed 125 $^{\circ}$ C under the worst case operating. Circuit design, component placement, PCB trace size and thickness, airflow and other cooling provision all affect the part temperature. Part temperature should be verified in the end application.

Note 7. : The rated current as listed is either the saturation current or the heating current depending on which value is lower.

### Current Characteristic

